

详细包装状态

■卷带规格

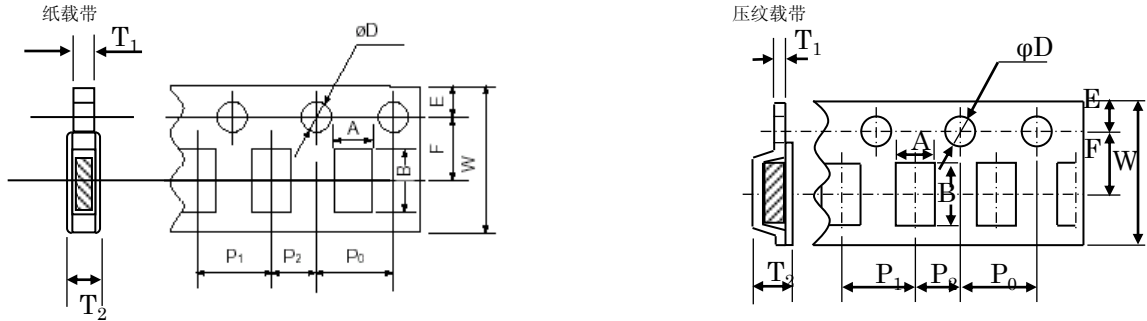

型号	专业 载带材质	A	B	W	F	E	P ₁	P ₂	P ₀	D	T ₁	T ₂
		±0.1	±0.1	±0.3	±0.05	±0.1	±0.1	±0.1	±0.1	±0.1	-	-
05	纸	0.65	1.1	8.0	3.5	1.75	2.0	1.0	4.0	φ1.5	0.7 Max	1.0 Max.
10		1.1	1.9	8.0	3.5	1.75	4.0	2.0	4.0	φ1.5	1.1 Max	1.4 Max.
20	压纹	1.65	2.4	8.0	3.5	1.75	4.0	2.0	4.0	φ1.5	0.6 Max	1.5 Max
30		2.0	3.6	8.0	3.5	1.75	4.0	2.0	4.0	φ1.5	0.6 Max	1.5 Max
40		2.8	3.6	8.0	3.5	1.75	4.0	2.0	4.0	φ1.5	0.6 Max	2.0 Max
70		3.6	4.9	12.0	5.5	1.75	8.0	2.0	4.0	φ1.5	0.6 Max	3.7 Max
80		5.4	6.1	12.0	5.5	1.75	8.0	2.0	4.0	φ1.5	0.6 Max	5.0 Max
85		5.3	6.8	16.0	7.5	1.75	8.0	2.0	4.0	φ1.5	0.6 Max	5.6 Max
90		6.9	8.2	16.0	7.5	1.75	12.0	2.0	4.0	φ1.5	0.6 Max	5.5 Max

■卷盘尺寸

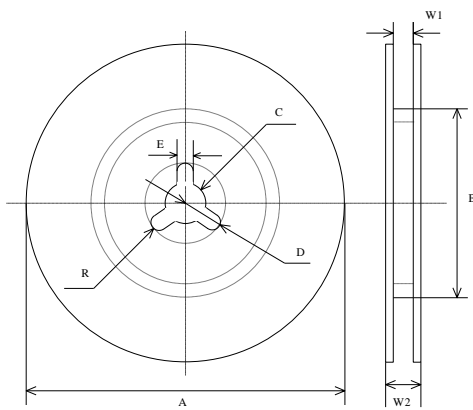

记号	尺寸 [mm]		
	型号		
	05, 10, 20, 30, 40	70, 80	90
A	φ178±2	φ178±2	φ178±2
B	≥φ50	≥φ50	≥φ50
C	φ13.0±0.5	φ13.0±0.5	φ13.0±0.5
D	10.5±0.4	10.5±0.4	10.5±0.4
E	2.0±0.5	2.0±0.5	2.0±0.5
W ₁	10±0.5	14±0.5	18±0.5
W ₂	14±0.5	18±0.5	22±0.5
R	1.0	1.0	1.0

■标准部品收纳数量(个/卷)

型号	AVS05 LVS05	AVS10 LVS10 CVG10	CVG20
T(mm)	0.5±0.2	0.8±0.2	1.25±0.2
数量	10,000	4,000	3,000

型号	CVG30		CVG40	
	T(mm)	1.0±0.2	1.25±0.2	1.0±0.2
数量	3,000	2,000	3,000	2,000

型号	CVA40	CVA70	CVA80	CVA90	CVX80
T(mm)	2.0max	2.0max	4.5max	4.5max	4.5max
数量	2,000	800	500~800	250	250

型号	CVH70	CVH80	
T(mm)	3.2max	3.2max	4.5max
数量	500	500	250