

Low frequency ripple-noise control and high frequency EMI control by 1 chip

Replacement example

low frequency/ripple control

- aluminum electrolytic capacitor 47~470 μ F
- tantalum capacitor 33~220 μ F
- conducting polymer 22~100 μ F
- MLCC 10~47 μ F

+

high frequency noise/EMI control

- Chip bead
- MLCC 1 μ F + 0.01 μ F
- 3-terminal EMI filter 1 μ F, 0.1 μ F

Low frequency ripple-noise control and high frequency EMI control are enabled by only 1 chip in the power supply line of most digital circuit.

low frequency/ripple control
+
high frequency noise/EMI control

High capacitance
3-terminal capacitor
4.7uF, 10uF, 22uF, 47uF

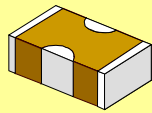

Parts reduction Example by high capacitance 3-terminal capacitor (aluminum electrolytic capacitor 100uF+MLCC 1uF+MLCC 0.1uF x 4)

Application example

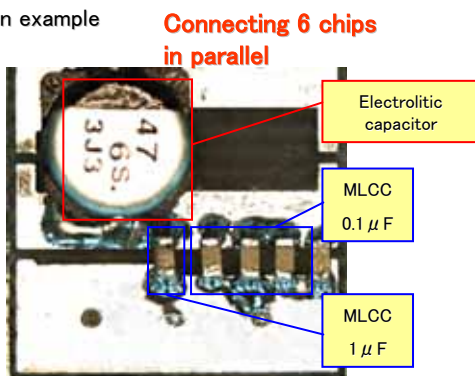

Number of parts=>1/6
Mounting cost=>1/6
Mounting space=>under 1/10
Noise removal effect=>UP

